

8.0 kW 60 Hz
e-QG™ Series
MGKBD
Gasoline

Leading the Way

- Quiet - the electronic Quiet Gasoline (e-QG) has the lowest noise level of any marine genset in its class
- User-friendly - the first marine genset with an advanced digital electronic control that provides extensive diagnostic information
- Self-protection - smart enough to protect even the raw water pump impeller
- Electronic frequency control - a must for digital appliances and computers requiring quality power
- Bulk head-type connections - quick and reliable for ease of installation, service and maintenance
- Customer support - largest worldwide certified Distributor/Dealer network in the industry with more than 60 years of marine experience
- Leading the way in marine genset design and development

Genset Ratings

Model	kW/kVA	Voltage	Amps	Phase	Hz	Engine RPM
8.0MGKBD	8.0/8.0	120	66.7	1	60 Hz	2400
		120/240	66.7/33.3	1	60 Hz	2400

Single phase output at 1.0 power factor. Rating conditions are 100 kPa (29.6 in Hg) barometric pressure, 30% relative humidity and 25° C (77° F) (ref. ISO 3046).

Genset Dimensions and Weights

Length	26.6 in (676 mm)
Width	23 in (583 mm)
Height	21.1 in (535 mm)
Weight (dry)	425 lb (193 kg)

Features

- Advanced digital electronic control providing extensive diagnostic capability
- Electronic governor allows the genset to maintain isochronous frequency control and close voltage regulation to provide quality power for digital appliances and computers
- Oil level check and fill accessed from control panel outside integral enclosure
- Single phase AC alternator with single or dual voltages
- Digital voltage regulator integral with control
- Start-run-stop switch with fuel pump priming mode for easy starting; run light and diagnostic indicator light
- Electric fuel transfer pump for priming and lift capability
- Engine starter with automatic start disconnect
- Freshwater cooling system with heat exchanger, expansion tank and coolant recovery system
- Water cooled exhaust mixing elbow
- AC mainline circuit breaker
- Shutdown with diagnostic indicator light for
 - High engine coolant temperature
 - High exhaust temperature
 - Low oil pressure
 - Over speed
 - Over voltage
 - Starter overcrank
 - Field current overload
 - CO monitor (not supplied with genset)
 - No raw water flow
 - Additional customer input and many more
- Running time meter
- Air intake silencer
- Full flow lube oil filter
- Oil drain valve and hose connection
- Electric fuel shut-off solenoid
- Fuel cooler for improved performance at high ambient temperatures
- Fuel filter
- Drip pan base capable of containing all genset fluids
- Captive focalized mounting system with vibration isolator mounts
- External mount tabs allow flexible mounting arrangement
- Bulk head type connections for ease of installation include fuel in, battery, raw water inlet, exhaust, genset ground (vessel bond)
- Integral enclosure for environmental protection
- Plug-in watertight connector for optional remote control
- Coolant overflow bottle to easily maintain coolant level
- Fire extinguisher access port
- Factory load tested
- E-coat process to protect sheet metal
- Five year Limited Warranty

Available Options

- 3 Amp (net) battery charging regulator

Accessories

- e-Series Digital Display - graphical LCD remote display for genset operating parameters and diagnostics
- Basic remote panel with start/stop switch with run (green) and control status (amber) lamps
- Deluxe remote panel with run (green) and control status (amber) lamps and volt meter
- Deluxe remote panel with start/stop switch with run (green) and control status (amber) lamps and hour meter
- Remote switch and harness (connection) only for customer panel
- Line circuit breakers for field conversion of AC voltage output
- Remote station harness pigtail
- Remote panel wire harness - 15 ft, 25 ft, 45 ft, 75 ft, 100 ft or 150 ft
- Siphon break kit
- Wet exhaust hose and stainless steel elbow
- Battery
- Water lift muffler
- Ship-to-shore selector switch, single phase, 2 or 3 wire output
- Cruise kit - maintenance parts - fuel filters, oil filters, raw water pump impellers, raw water pump belt, spark plugs, oil filter wrench, and plastic container
- Bulkhead battery terminal boots



e-Series Digital Display

Outline Drawing

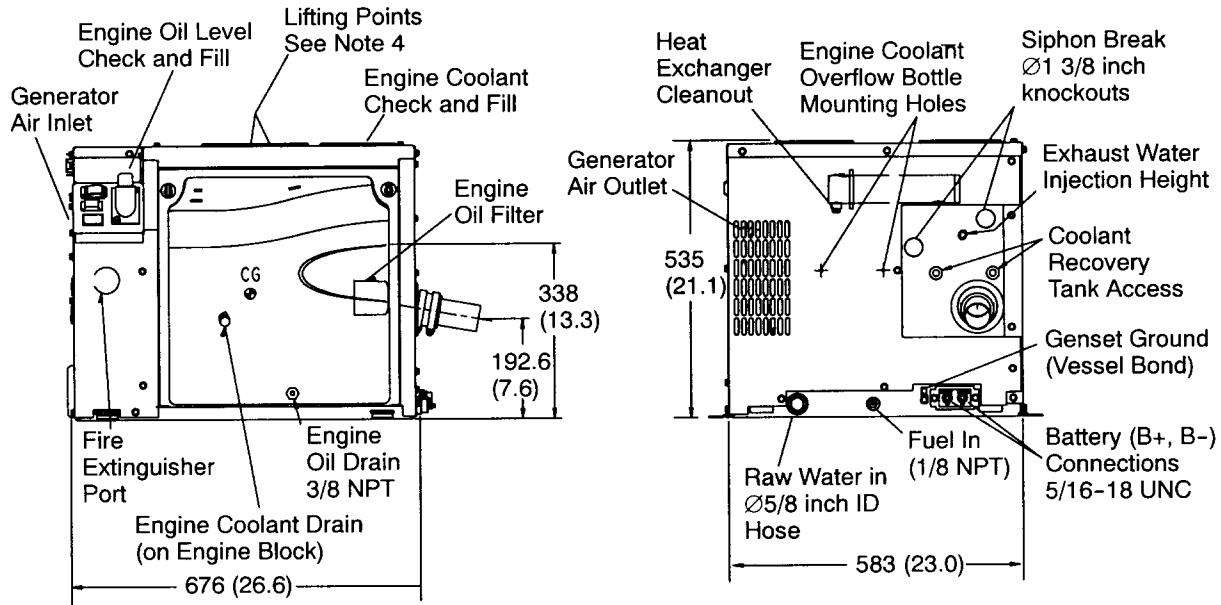

Note:
 1. Dimensions in () are in Inches
 2. 25.4 (1.00) minimum clearance required for airflow at air inlet and outlet
 3. 4 tabs (one at each corner) minimum required when using external mounting tabs
 4. Two point lift is required

This outline drawing is provided for general reference only and is not intended for design or installation. See installation manual and obtain outline drawing number 500-3363 for more information (available from your Distributor/Dealer).

Engine Detail

Design 4-cycle, water-cooled gasoline
Cylinders 3
Bore 2.68 in (68 mm)
Stroke 2.68 in (68 mm)
Displacement 45.2 in³ (740 cm³)
Compression Ratio 9.2:1
Max Fuel Lift 4 ft (1.2 m)
Lube Oil Capacity 2.2 qt (2.1 L)
Coolant Capacity 3.3 qt (3.1 L)
Coolant Flow Rate
 60 Hz: 3.5 Gal/min (13 L/min)

Raw Water Flow Rate
 60 Hz: 5 Gal/min (19 L/min)
Starting System 12 V
Power (Max) SAEJ1349
 at 2400 RPM 18.5 hp (13.8 kW)

Max Raw Water Lift 4 ft (1.2 m)

Fuel Consumption
 Gasoline, Gal/hr (L/hr)

	MGKBD
	60 Hz
No Load	0.35 (1.3)
1/4 Load	0.51 (1.9)
1/2 Load	0.77 (2.9)
3/4 Load	1.05 (3.9)
Full Load	1.4 (5.3)

Alternator Detail

Design Onan revolving field, 2-pole, drip-proof construction
Voltage Regulator Integral with the digital control

Stator Skewed stator and 2/3 pitch windings minimize field heating and voltage harmonics; resin-coated for corrosion protection

Rotor Dynamically balanced assembly; supported by pre-lubricated, maintenance-free ball bearings

Cooling Rotor mounted centrifugal blower
Insulation System Class H per NEMA MG1-1 -1.65 and BS5000

Genset Detail

Operating Environment Gensets are durability tested at maximum ambient; air temperature: 122° F (50° C); raw water temperature 100° F (37.8° C)

Frequency Regulation Isochronous
Random Frequency Variation Will not exceed +/-0.5% of its mean value for constant loads from no load to full load
Voltage Regulation +/-1.5%

Sound Level
 69 dB(A) at 60 Hz*
 * Full load at 1 m

Warranty Policy

The Onan express, written Limited Warranty covers virtually everything except routine maintenance for the first two years you own your marine generator set and covers parts and labor on major power train and generator set parts during the third through fifth years.

For complete Onan Limited Warranty details see your Onan Distributor/Dealer.

After Sale Support

GENUINE ONAN MAINTENANCE PARTS AND PRODUCTS - For your ongoing satisfaction and the dependability of your Onan marine gensets, Onan offers a complete line of replacement and tune-up parts, accessories and oil and maintenance chemicals. Onan marine parts are packaged for correct selection and convenient on-board storage.

EASY TO LOCATE CERTIFIED ONAN SERVICE AND PARTS DEALERS - Onan has the largest and best-trained worldwide certified Distributor/Dealer network in the industry, offering on-time parts and service and installation assistance. Onan Distributor/Dealers stock and sell commonly used Onan marine genset maintenance parts, accessories and products, plus operator manuals and literature on current Onan gensets. They can help you select and install the right genset for a new vessel or accessories on older models, or provide answers to questions on proper operation and maintenance procedures.

MANUALS - Installation, operators and parts manuals are shipped with the genset. To obtain additional copies or other manuals for this model, see your Onan Distributor/Dealer.

Standards and Testing



National Marine Manufacturers Association (NMMA) members produce every conceivable product used by recreational boaters. NMMA provides a wide variety of programs and services including technical expertise, standards monitoring, government relations advocacy and industry statistics.

The American Boat and Yacht Council (ABYC) develops standards and recommended practices for designing, constructing, equipping and maintaining small pleasure and commercial craft.

This generator set was designed and manufactured in facilities certified to ISO 9001.

This genset complies with the fire test and the ignition protection requirements of the US Coast Guard safety standards and ISO standards 10088 and 8846.

Contact your Distributor/Dealer for more information



To easily locate the nearest Onan Distributor/Dealer, or for more information, contact Onan at 1-800-888-ONAN or 763-574-5000; 1400 73rd Avenue N.E., Minneapolis, MN 55432 U.S.A.; fax 763-528-7242; email: feedback@onan.com; www.onan.com.

Cummins Power Generation is a subsidiary of Cummins Inc. Onan is a registered trademark of Cummins Inc. **WARNING:** Backfeed to a utility system can cause electrocution and/or property damage. Do not connect to building electrical except through approved device or after building main breaker is open.